

Opaque reflexes of successive-cyclic movement: Ordering final vs. intermediate movement steps*

Doreen Georgi (Leipzig University)
georgi@uni-leipzig.de

1 Introduction

OVERALL GOAL:

The present research aims at exploring transparent and opaque interactions of syntactic operations within the Minimalist framework in order to gain insights into the nature of elementary operations and their mode of application (simultaneous vs. sequential application, extrinsic vs. intrinsic application).

OPAQUE INTERACTION TYPES (Kiparsky 1968; 1971; 1973*a*):

- (1) a. Counter-feeding (underapplication):
 - (i) A rule R_1 creates the context for the application of a rule R_2 and should thus feed R_2 .
 - (ii) Empirical evidence: R_2 has not applied although R_1 has.
 - (iii) \hookrightarrow A rule has not applied although its context is given.
- b. Counter-bleeding (overapplication):
 - (i) A rule R_1 destroys the context for the application of a rule R_2 and should thus bleed R_2 .
 - (ii) Empirical evidence: R_2 has applied although R_1 has as well.
 - (iii) \hookrightarrow A rule has applied although its context is not given.

CONFIGURATION UNDER INVESTIGATION:

Merge and Agree are triggered by a single head H ; $[\bullet F \bullet]$ triggers Merge, $[*F: \square *]$ triggers Agree (the notation of features is taken from Sternefeld 2006; Heck and Müller 2007).

- (2) $H \{ [\bullet F \bullet], [*F: \square *] \}$

QUESTION:

If the context for both operations is met after H is merged, do they apply simultaneously or sequentially?

- The *Earliness Principle* (Pesetsky 1989) favors simultaneous application because this is the only way to apply both operations as soon as possible.
- However, simultaneous application can only derive opaque interactions, but not transparent ones (Kisseberth 1972*a*; Kenstowicz and Kisseberth 1979).
- Observation: There are feeding and bleeding relations between Merge and Agree in this configuration (illustrated in (3) for downward Agree: the probe must c-command the goal). These interactions require sequential application and thus ordering of the operations.

*For more data, derivations and extensions of the approach to downward Agree and other types of Merge see Georgi (2014). For valuable comments I would like to thank Anke Assmann, Fabian Heck, Philipp Weisser, Gereon Müller, and Jason Zentz; I am indebted to Peter Muriungi, Harold Torrence and Coppe van Urk for answering data questions. This research is supported by the DFG (Deutsche Forschungsgemeinschaft) within the project “Lokale Modellierung nicht-lokaler Abhängigkeiten in der Syntax” (Local modeling of non-local dependencies in syntax): <http://www.uni-leipzig.de/~lomo>.

(3) Merge > Agree (bleeding):

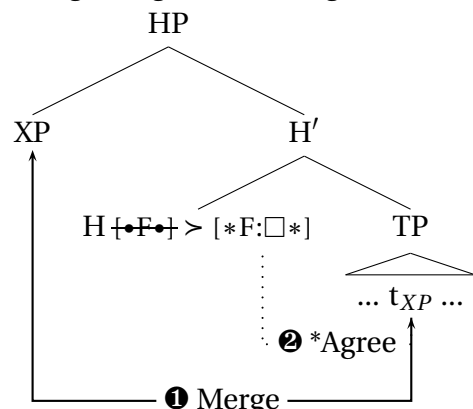

(4) Agree > Merge (counter-bleeding):

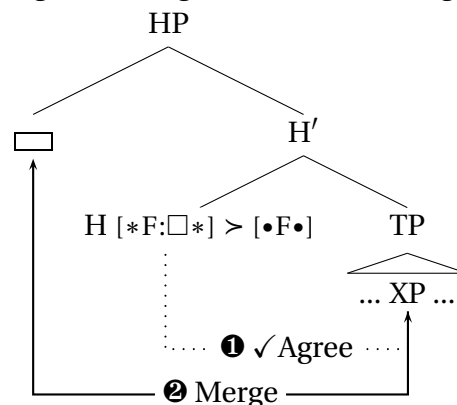

Examples: see e.g. Anand and Nevins (2005); Bruening (2005); van Koppen (2005); Asarina (2011); Halpert (2012); Kalin and van Urk (2012); Richards (2013)

Example: e.g. subject-verb agreement in English (EPP-movement of the subject DP to SpecTP counter-bleeds ϕ -Agree T-DP)

The order of operations is assumed to be language-specific, i.e. there is a parameter that can be set either to Merge > Agree or Agree > Merge (see also Heck and Müller 2007; Lahne 2008a; Müller 2009; Assmann et al. 2012).

PRESENT TALK: COUNTER-FEEDING INTERACTIONS:

A paradox:

There is empirical evidence suggesting that Merge operations, when triggered by the same head H, apply at different points of the derivation *within a single language*. We can see this once Merge is interleaved with Agree: Some Merge operations apply *before* Agree (feeding/bleeding it), while others apply *after* Agree (counter-feeding/-bleeding it):

(5) Merge > Agree > Merge

Analysis:

This is paradoxical if Merge is a uniform operation. This paradox can be resolved if there are two different types of Merge that can be ordered differently relative to Agree:

(6) Merge₁ > Agree > Merge₂

Claim

- Patterns of reflexes of successive-cyclic movement exhibit opacity effects: some movement steps *feed* Agree between a head H and the XP moved to SpecHP, whereas others *counter-feed* it.
- The split is between final and intermediate movement steps in a chain.
- The opacity is resolved if these movement types are triggered by designated features, and can thus apply at different points of the derivation wrt. Agree.
- I thus argue for a more fine-grained typology of Merge and sequential application of syntactic operations triggered by a single head.
- Cross-linguistic variation suggests that the order of operations is extrinsic.

2 Reflexes of successive-cyclic movement

- A great deal of empirical evidence has been accumulated since the 1970s for the assumption that movement applies successive-cyclically: morphophonological, syntactic and semantic reflexes.
- Reflexes appear either in intermediate positions or on heads that project such a position.
- I will exclusively be concerned with reflexes of the latter type (morphophonological, syntactic reflexes) because they involve Agree between the head and the moving XP.
- Reflexes of the former type are excluded (copying, stranding, semantic reflexes).

2.1 Analysis of reflexes of movement

A COMMON PATTERN:

(7) *A reflex R on the C-head of every clause on the path of movement:*

[_{CP1} XP_{wh} [_{C'} **C-R** ... [_{CP2} t_{wh} [_{C'} **C-R** ... [_{CP3} t_{wh} [_{C'} **C-R** ... t_{XP}]]]]]]

(8) *u-construction in Wolof (Torrence 2012: 1151, 1171):*

a. Ø_k **k-u** ____k togg ceeb ak jën

Q CL-u cook rice and fish

'Who cooked rice and fish?'

short wh-movement

b. Ø_k **y-u** jigéén j-i togg ____k

Q CL-u woman CL-DEF.PROX cook

'What(pl) did the woman cook?'

short wh-movement

c. [_{CP} Ø_k **k-u** Kumba wax [_{CP} ne **k-u** Isaa defe [_{CP} ne **k-u** Maryam dóór ____k]]]

Q CL-u Kumba say FRC CL-u Isaa think FRC CL-u Maryam hit

'Who did Kumba say that Isaa thought that Maryam hit?'

long wh-movement

EVIDENCE THAT THIS REFLEX IS RELATED TO MOVEMENT:

- island-sensitivity: Movement types that trigger a reflex are subject to island constraints (wh-islands, complex NP islands).
- The reflex only shows up on C heads that are crossed by overt \bar{A} -movement.
 - in-situ constructions: There is no reflex on any C head with wh-in-situ.
 - partial \bar{A} -movement: reflex only on C heads below the overt landing site of XP.
 - Movement within the matrix clause: no reflex on C heads of the embedded clause(s).
- strong / weak cross-over effects of XP-movement

ASSUMPTIONS:

- Reflexes of movement are the result of an agreement relation between a head H and an XP moved to SpecHP (see e.g. Torrego 1984; Chung and McCloskey 1987; McCloskey 1990; Rizzi 1990; Schneider-Zioga 1995; Kinyalolo 1991; Collins 1993; Henry 1995; Chung 1998; Torrence 2012).

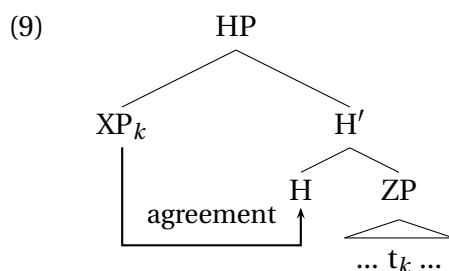

- The distribution in (7) follows if the XP moves successive-cyclically; it makes a stop-over in SpecCP of every clause on the way to its final landing site.

2.2 Patterns of reflexes of movement

(10) $[\text{CP}_1 \text{What}_k \text{ do you think } [\text{CP}_2 \text{---}_k \text{ that Mary believes } [\text{CP}_3 \text{---}_k \text{ that Bill bought } \text{---}_k]]]]$
final *non-final* *non-final*

(11) *Patterns of reflexes of movement:*

- a. PI: reflexes in the final and non-final clauses
 $[\text{CP}_1 \text{XP}_{wh} [\text{C}' \text{C-R} \dots [\text{CP}_2 \text{C-R} \dots [\text{CP}_3 \text{C-R} \dots \text{t}_{XP}]]]]$
- b. PII: reflexes solely in the final clause
 $[\text{CP}_1 \text{XP}_{wh} [\text{C}' \text{C-R} \dots [\text{CP}_2 \text{C} \dots [\text{CP}_3 \text{C} \dots \text{t}_{XP}]]]]$
- c. PIII: reflexes solely in non-final clauses
 $[\text{CP}_1 \text{XP}_{wh} [\text{C}' \text{C} \dots [\text{CP}_2 \text{C-R} \dots [\text{CP}_3 \text{C-R} \dots \text{t}_{XP}]]]]$
- d. PIV: no reflex in any clause
 $[\text{CP}_1 \text{XP}_{wh} [\text{C}' \text{C} \dots [\text{CP}_2 \text{C} \dots [\text{CP}_3 \text{C} \dots \text{t}_{XP}]]]]$

(12) *Pattern II: no-marking in Duala (Epée 1976: 194-195):*

- a. Kuo a po njika ponda
 Kuo 3SG come which time
 'At what time will Kuo arrive?' *wh-in-situ*
- b. njika ponda Kuo a po **no** ___
 which time Kuo 3SG come *no*
 'At what time will Kuo arrive?' *short wh-movement*
- c. njika buna o ta **no** o kwalane mba na o mende timba ___
 which day you PST *no* you tell me that you FUT return
 'When did you tell me that you would return?' *long wh-movement*

(13) *Pattern III/VI: Complementizer agreement in Wolof an-chains (Torrence 2012: 1173f.):²*

- a. $[\text{CP} \text{K-an}_k \text{l-a-}\tilde{\text{n}}\text{u} \text{ wax } [\text{CP} \text{k-u} \text{ jigéén } \text{j-i} \text{ foog } [\text{CP} \text{k-u} \text{ ma } \text{dóór } \text{---}_k]]]]$
 CL-an EXPL-a-3PL say CL-u woman CL-DEF.PROX think CL-u 1SG hit
 'Who did they say that the woman thinks that I hit?' *PIII*
- b. $[\text{CP} \text{K-an}_k \text{l-a-}\tilde{\text{n}}\text{u} \text{ wax } [\text{CP} \text{l-a} \text{ jigéén } \text{j-i} \text{ foog } [\text{CP} \text{l-a} \text{ ma } \text{dóór } \text{---}_k]]]]$
 CL-an EXPL-a-3PL say EXPL-a woman CL-DEF.PROX think EXPL-a 1SG hit
 'Who did they say that the woman thinks that I hit?' *PIV*

(14) *Languages with pattern I:*

C-Agr (e.g. Wolof <i>u</i> -chains)	Torrence (2012)
C-selection (e.g. Modern Irish)	McCloskey (1979; 1990; 2002)
wh-agreement (e.g. Chamorro)	Chung (1998)
tonal morphology (Kikuyu)	Clements and Ford (1979); Clements (1984 <i>a</i> ; <i>b</i>)
focus marking (e.g. Malay)	Sabel (2000)
meN-deletion (e.g. Malay, Indonesian)	Sabel (2000); Saddy (1991)
inversion (e.g. Spanish)	Torrego (1984)

²See Torrence (2013); Martinović (2013) for arguments that *l-* is a default class marker.

(15) *Languages with pattern II:*

phenomenon	references
C-Agr (e.g. Chamorro)	Chung (1998)
pronoun choice (Ewe)	Collins (1993; 1994)
focus marking (Indonesian)	Saddy (1991)
<i>no</i> -marking (Duala)	Epée (1976 <i>a</i> ; <i>b</i>)

(16) *Languages with pattern III:*

phenomenon	references
preverbal focus marking (Kitharaka)	Muriungi (2005); Abels and Muriungi (2008)
C-Agr (Wolof <i>an</i> -chains)	Torrence (2012)
<i>ke</i> -stranding (Dinke)	van Urk and Richards (2013)
obligat. extraposition (German, Basque)	Müller (1999); Ormazabal et al. (1994)

- Pattern I figures prominently in the literature on reflexes of movement.
- Patterns II and III are much less discussed; especially in recent formal work, pattern III is virtually absent.
- The existence of pattern II is mentioned in passing, but it is not analysed; or it is considered not to be a “real” reflex of movement (Boeckx 2008; Lahne 2008*b*).
- Only exception: Reintges et al. (2006) introduce and analyse patterns I and II; however, they conclude that “no other patterns are attested” (p.167), contrary to fact.

CLAIM:

- In languages with a pattern II or a pattern III reflex, movement also applies successive-cyclically, exactly as in pattern I languages. Some movement steps just do not result in a reflex.
- Hence, patterns II and III are opaque: Movement to SpecHP can feed Agree, but sometimes it does not (counter-feeding), depending on whether the movement step is final or intermediate.

2.3 Analyses of pattern II without opacity

2.3.1 No reflex – no movement

HYPOTHESIS:

There is no reflex of movement in non-final clauses because there are no intermediate landing sites in these clauses.

- HI: XP is base-generated in its surface position.
- HII: XP moves to its surface position in one fell swoop (see e.g. Epée 1976*a*; *b* on Duala, Cheng 2006 on Bantu languages, Takahashi and Gracanin Yuksek 2008 on Haitian Creole, Martinović 2013 on Chamorro C-agreement).

EVIDENCE FOR BASE-GENERATION:

The dependency that triggers a pattern II reflex is not island-sensitive.

Irish: In \bar{A} -dependencies, default complementizer *go* is replaced either by *aL* or by *aN*. *aL*-chains exhibit pattern I, whereas *aN*-chains follow pattern II. *aN*-chains seem to involve base-generation because in contrast to *aL*-chains, the dependency that triggers *aN* is neither island-sensitive nor does it induce cross-over effects, cf. (17) vs (18).

- (17) *Irish aL-chains, pattern I (McCloskey 1979: 30, 54, McCloskey 1990: 110):*
- a. [an t-úrscéal]_i [CP [OP_i]_k a mheas mé [CP a dúirt sé [CP a thuig sé ____k]]]
 the novel aL thought I aL said he aL understood he
 ‘the novel that I thought he said he understood’ *long relativization*
- b. *an fear_i [CP [OP_i]_k a phóg mé an [NP bhean_j [CP [OP_j] a phós ____k]]]
 the man aL kissed I the woman aL married
 ‘the man who I kissed the woman who married’ *CNP island*
- c. *[fear_i] [CP [OP_i]_k a d’fhág a_i bhean ____k]
 man aL left his wife
 ‘a man that his wife left’ *WCO*
- (18) *Irish aN-chains, pattern II (McCloskey 1979: 33-34, McCloskey 1990: 110, McCloskey 2002: 190):*
- a. an rud_i [CP OP_i ar dúirt sé [CP go gcoinneodh sé ceilte é_i]]
 the thing aN said he go keep.COND he hidden it
 ‘the thing that he said he would keep (it) hidden’ *long relativization*
- b. sin teanga_i [CP OP_i a mbeadh meas agam ar [NP duine_j ar bith [CP OP_j a tá ábalta ____j í_i a labhairt]]]
 that language aN would.be respect at.me on person any aL is able
 it to speak
 ‘That is a language that I would respect anyone who could speak it.’ *CNP-island config.*
- c. fear_i [CP OP_i ar fhág a_i bhean é_i]
 man aN left his wife him
 ‘a man that his wife left’ *WCO configuration*

ARGUMENT AGAINST HI (BASE-GENERATION):

The base-generation analysis of pattern II cannot hold for all languages with this pattern: The dependencies that result in a pattern II reflex in Chamorro (complementizer agreement), Duala (*no*-marking), Ewe (subject pronoun choice) and Malay (focus marking) are island-sensitive.

- Duala: \bar{A} -dependencies (wh-movement, focus movement, relativization) triggers the occurrence of the marker *no* after the first verbal element of the clause in which the moved XP surfaces, cf. (19-a). These dependencies are island-sensitive, cf. (19-b-c)

(19) *Island-sensitivity in Duala (Bilola 1993: 70f.):*

- a. moto_i [CP nyena_i na mongole no [CP na o kwadi [CP na o wen ____k]]]
 man who I think NO that you say that you see
 ‘the man who I think that you said that you saw’
- b. *moto_i [CP [nyena_i]_k na neimbi no [NP mbo_j [CP [nyenat_j]_n ____n e kuko ____k]]]
 man who I recognize NO dog which SM bit
 ‘the man who I recognized the dog which bit (him)’ *CNP island*
- c. *moto_i [CP [nyena_i]_k na nyaka no [CP [nja mmuto]_n ____n bai ____k]]
 man who I am.astonished NO who woman married
 ‘the man who I wonder which woman married (him)’ *wh-island*

- In Ewe, the default form of the 3rd person subject pronoun *é* changes to *wò* under \bar{A} -movement of an XP (wh-movement, focus movement, relativization), cf. (20-a-b). Under long extraction, the change is obligatory in the final clause but optional in non-final clauses (pattern I vs pattern II), cf. (20-c). The \bar{A} -dependencies that trigger this reflex are island-sensitive, cf. (20-d).

(20) *Subject pronoun choice un Ewe (Collins 1993: 157, 177ff.):*

- a. [$\acute{e}/w\grave{o}$] fo K \textcirc si
 he hit K \textcirc si
 'He hit K \textcirc si.' *declarative*
- b. [_{CP} Kofi bi ϵ [_{CP} be lamata_k [* $\acute{e}/w\grave{o}$] fo K \textcirc si _____k]]
 Kofi asked C why he hit K \textcirc si
 'Kofi asked why he hit K \textcirc si.' *embedded question*
- c. [_{CP} [K \textcirc si ϵ]_k me gbl \textcirc [_{CP} be [$\acute{e}/w\grave{o}$] fo _____k]]
 K \textcirc si FOC I said C he hit
 'K \textcirc si, I said that he hit.' *DO focus movement*
- d. *Kofi_k ϵ me nya [_{NP} ame_i [_{CP} [xe_i] fo _____k]]
 Kofi FOC I know person which hit
 'As for Kofi, I know the person who hit (him).' *CNP island*

ARGUMENT AGAINST HII (MOVEMENT IN ONE FELL SWOOP):

Multiple reflexes: A single instance of long \bar{A} -movement can have two different types of reflexes. If a pattern I and a pattern II reflex co-occur (e.g. wh-agreement + C-agreement in Chamorro, *meN*-deletion +. focus marking in Indonesian), movement would have to apply successive-cyclically (to derive PI) and in one fell swoop (to derive PII) at the same time.

Example: Chamorro

- \bar{A} -movement results in wh-agreement on the verb (a special morphological marking that replaces the regular subject-verb-agreement) and a special form of the complementizer. Wh-agreement exhibits pattern I, C-agreement exhibits pattern II.

(21) *Abstract patterns of a pattern I and a pattern II reflex in Chamorro:*

[_{CP1} XP_{wh} [_C **C-R** ... **v-R** ... [_{CP2} C ... **v-R** [_{CP3} C ... **v-R** ... t_{XP}]]]]

- Without operator movement: The choice of the complementizer depends on (i) the finiteness of the verb (finite vs. non-finite), (ii) the clause type (interrogative vs. non-interrogative) and (iii) the embedding status (root vs. embedded clause).

(22) *Chamorro complementizers in clauses without operator movement (Chung 1998: 223):*

syntactic context	form of C
[-fin] / [+fin, +root, -Q]	\emptyset
[+fin, -root]	<i>na</i>
[+fin, +Q]	<i>kao</i>

- With operator movement: The form of the complementizer depends on the properties of the \bar{A} -moved phrase, among other things its category.

(23) *Chamorro: complementizers used in clauses with operator movement (Chung 1998: 224):*

syntactic context	form of C
[+N, -locat]	\emptyset
[-N]	<i>na</i> (Guam) or <i>nai/ni</i> (Saipan)

- Example with wh-agreement (pattern I) and complementizer agreement (pattern II):

(24) *Complementizer choice in sentences with operator movement (Chung 1998: 230):*

[Manu na lepblu]_k Ø malagu'ñiha [CP na u-taitai _____k]
 which L book C WH.OBL.want-AGR C WH.obj.AGR-read
 'Which book do they want to read?' (lit: 'Which book do they want that they should read?')

(matrix clause: wh-XP = NP > Ø-C; embedded clause: +fin, -root > na-C)

Pattern III also shows that the absence of a reflex of movement cannot generally be due to the absence of movement. The dependencies that trigger a pattern III reflex in the languages in (16) are island-sensitive, so they clearly involve movement. The reflexes in non-final clauses show that movement is successive-cyclic. But still, there is no reflex in the final clause.

CONCLUSION:

Hypotheses HI and HII are not tenable for all pattern II languages. At least in some, the \bar{A} -dependency involves successive-cyclic movement.

2.3.2 No reflex – no Agree?

HYPOTHESIS III:

There are intermediate movement steps in pattern II languages, but there is no agreement relation between the head H and the XP moved to SpecHP if SpecHP is an intermediate landing site.

ARGUMENT AGAINST HIII:

- In some pattern II languages, the exponent we find under \bar{A} -movement in the final clause is not absent, but replaced by a default exponent, see the example from Wolof *u*-chains in (25):

(25) *Patterns of complementizer agreement in Wolof u-chains (Torrence 2012: 1173):*

- a. [CP Ø_k k-u Kumba wax [CP ne k-u Isaa defe [CP ne k-u Maryam dóór _____k]]]
 Q CL-u Kumba say FRC CL-u Isaa think FRC CL-u Maryam hit
 'Who did Kumba say that Isaa thought that Maryam hit?' *PI*
- b. [CP Ø_k k-u Kumba wax [CP ne I-a Isaa defe [CP ne I-a Maryam dóór _____k]]]
 Q CL-u Kumba say FRC EXPL-a Isaa think FRC EXPL-a Maryam hit
 'Who did Kumba say that Isaa thought that Maryam hit?' *PII*

- The default marker indicates that there is a probe on the complementizer that attempts to get valued; if valuation by the moving XP fails, a default value is inserted.

CONCLUSION:

The absence of a reflex of movement on a head H cannot generally be the result of the lack of a probe on H, contra hypothesis HIII.

CONSEQUENCE:

At least in some pattern II languages, movement applies successive-cyclically, exactly as in pattern I languages, and the head that projects the intermediate movement step bears a probe. Hence, in the configuration in (9), movement should feed Agree, but sometimes it does not.

Thus, pattern II and pattern III are opaque: Movement of XP to SpecHP can feed Agree between XP and H, but sometimes, Agree fails.

3 An ordering approach to opacity

MAP:

1. Desideratum: provide a uniform analysis for all patterns of morphological reflexes of movement that also captures mixed patterns.
2. Observation: Patterns II and III are opaque; agreement between the moving XP and the head that projects a landing site for XP is sometimes counter-fed.
3. Proposal: Opacity is resolved by ordering of operation-inducing features on a head (if $A > B$ leads to feeding/bleeding, the reverse order $B > A$ leads to counter-feeding/-bleeding).

CORE IDEA:

Final and intermediate movement steps apply at different points in the derivation: Movement steps that apply before Agree feed Agree, whereas movement steps that apply after Agree thus counter-feed Agree. If Merge were a uniform operation, this would lead to the paradoxical situation in (26):

(26) Merge $>$ Agree $>$ Merge

Hence, there must be a distinction between final and intermediate movement steps that the ordering principle can refer to.

(27) Merge₁ $>$ Agree $>$ Merge₂

I assume that the Merge types are distinguished by their triggers: intermediate movement steps are triggered by edge features, a special type of structure-building feature (Chomsky 2000 et seq.).

3.1 Assumptions

- The morphological reflex = spell-out of a feature value that is the result of agreement between a head H and an XP moved to SpecHP.
- Internal Merge is driven by structure-building features [$\bullet F \bullet$].
- Movement is subject to the PIC. Every phrase is a phase.

(28) *PIC (Chomsky 2000: 108):*

In phase α with the head H, the domain of H is not accessible to operations outside α ; only H and its edge are accessible to such operations.

- Intermediate movement steps have a designated trigger, the edge feature [$\bullet EF \bullet$] (Chomsky 2000; 2001). A head is assigned an edge feature if required.
- Agreement is the result of the operation Agree, triggered by probe features [$*F:\square*$]:

(29) *Definition of Agree Chomsky (2000; 2001):*

Agree between a probe P and a goal G applies if

- a. P and G are in an asymmetric c-command relation,
- b. P has an unvalued feature [$*F:\square*$] and G has a matching valued feature [F],
- c. G is the closest matching goal for P.
- d. Result: G values P.

- For the cases at hand, I assume that Agree applies **upwards**, in a Spec-head configuration. This explains why agreement is sensitive to the post-movement configuration and why the reflex is tied to overt movement, viz. absent in in-situ constructions (Baker 2008).

- I follow Bošković (2007) in assuming that Agree is not subject to the PIC.
- If a probe cannot find a matching goal, it does not cause a crash of the derivation. Unvalued probe features receive a default value or are deleted by default (Řežáč 2004; Anand and Nevins 2005; Preminger 2011).
- Only *a single operation* can apply at any given stage of the derivation. Hence, operation-inducing features on a head must be ordered.
- Ordering takes place in the numeration. The order is determined by language-specific ordering principles that order types of structure-building features relative to probe features.
- Operation-inducing features are ordered on a stack of which only the topmost feature is accessible. Effect = *strict ordering hypothesis* (see e.g. Chomsky 1965; Kisseberth 1972a; Kenstowicz and Kisseberth 1979): Every operation-inducing feature can only attempt to trigger an operation at a certain point of the derivation, viz. when it is on top of the stack, but neither before or after that point (even if its context would be met then).

(30) a. Abstract ordering statement:

$$[\bullet F \bullet] > [*F: \square *] > [\bullet EF \bullet]$$

b. Ordering of a probe and a final movement step trigger on C:

$$C \begin{bmatrix} [\bullet WH \bullet] \\ [* \phi *] \end{bmatrix}$$

- Variation is the result of *reordering* of operation-inducing features.
- The features of a head are realized postsyntactically by the insertion of vocabulary items (*Distributed Morphology*, Halle and Marantz 1993; 1994).

CONSEQUENCES:

- Movement steps that apply *before* Agree feeds upward Agree.
- Movement steps that apply *after* Agree counter-feed upward Agree; they come too late to bring the potential goal into the search domain of the probe – the probe is already discharged at this point (by default).

3.2 Abstract derivations

(31) *Internal Merge feeds Agree:*

a. Initial structure

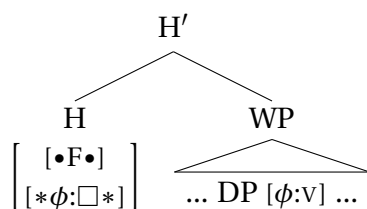

b. First step: Merge, [$\bullet F \bullet$] discharged

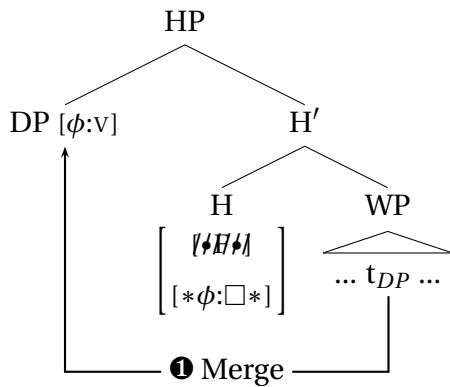

c. Second step: Agree

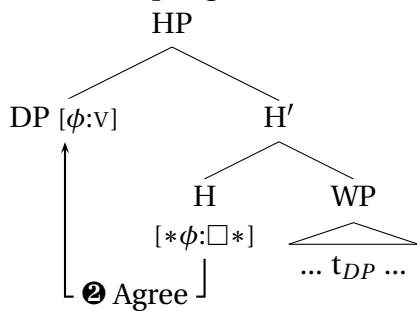

d. Result: probe valued

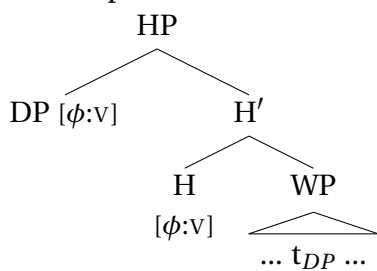

(32) *Internal Merge counter-feeds Agree:*

a. Initial structure

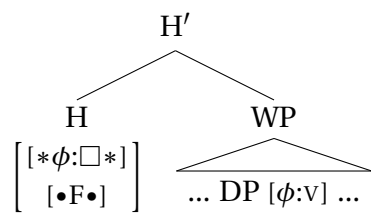

b. First step: Agree, no goal found

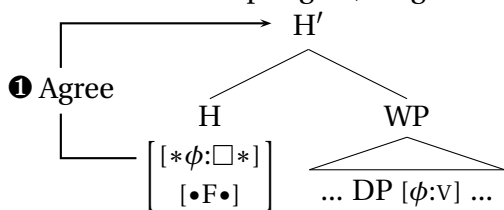

c. Last resort: probe deleted by default

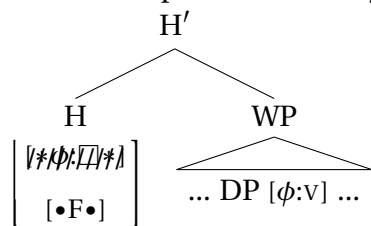

d. Second step: Merge, [•F•] discharged

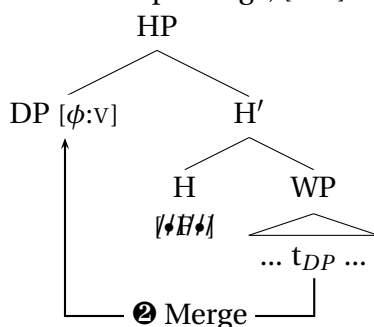

VARIATION:

If final and intermediate movement steps have different triggers, the logically possible orderings of the two types of movement triggers and a probe feature predict the four patterns of reflexes of movement:

(33) *Orderings of the two types of Merge triggers relative to a probe feature*

order of features	interactions		pattern
	final steps	intermediate steps	
a. [•F•], [•EF•] > [*F:□*]	feed Agree		P I
b. [•F•] > [*F:□*] > [•EF•]	feed Agree	counter-feed Agree	P II
c. [•EF•] > [*F:□*] > [•F•]	counter-feed Agree	feed Agree	P III
d. [*F:□*] > [•F•], [•EF•]	counter-feed Agree		P IV

3.3 Mixed patterns

- A single instance of \bar{A} -movement can have several reflexes which follow different patterns.
- Example: Chamorro – a pattern I reflex (wh-agreement) and a pattern II reflex (complementizer agreement) co-occur.
- Such multiple reflexes are a challenge for the theories presented in section 2.3.
- Solution in the ordering approach: As long as the reflexes are the result of two different Agree relations (different features are involved), the probe features can be interleaved with the Merge triggering features:

(34) *A pattern I and a pattern II reflex co-occur:*

[•F•] > [*F:□*] > [•EF•] > [*L:□*]

(35) *Ordering statement in Chamorro (patterns I and II co-occur):*

[•F•] > [*CAT:□*] > [•EF•] > [*CASE:□*]

- Consequence: [*F:□*]-Agree is fed by final movement steps only (pattern II); [*L:□*]-Agree is fed by both final and intermediate movement steps

3.4 Optionality

- In many languages, the reflex of movement is optional; result: alternation of patterns.
- examples: Ewe, Wolof *u*-chains (PI vs. PII, cf. (20-c), (25)), Wolof *an*-chains (PIII vs. PIV, cf. (13))
- Optionality in the literature on reflexes of movement: very few accounts, Collins (1993) (AIII approach): operations on traces are optional
- Optionality of operation-inducing features: Merge cannot be optional, \bar{A} -movement always takes place, whether we find pattern I or II / pattern III or IV
- Solution in the ordering approach: partial ordering – the order of a structure-building feature is not fixed in the language-specific ordering principle.
- Consequence: The location of the feature on the stack is free, it can be put anywhere; what is relevant for the pattern is whether it ends up above or below the probe feature.

(36) *Partial ordering for pattern I / II alternation:*

$[\bullet F \bullet] \succ [*F:\square*] \quad | \quad [\bullet EF \bullet]$

(37) *Possible orderings based on (37):*

a. $[\bullet F \bullet], [\bullet EF \bullet] \succ [*F:\square*]$

PI: intermediate steps apply before Agree

b. $[\bullet F \bullet] \succ [*F:\square*] \succ [\bullet EF \bullet]$

PII: intermediate steps apply after Agree

(38) *Partial ordering for pattern III / IV alternation:*

$*F:\square* \succ [\bullet F \bullet] \quad | \quad [\bullet EF \bullet]$

(39) *Possible orderings based on (39):*

a. $[\bullet EF \bullet] \succ [*F:\square*] \succ [\bullet F \bullet]$

PIII: intermediate steps apply before Agree

b. $*F:\square* \succ [\bullet F \bullet], [\bullet EF \bullet]$

PIV: intermediate steps apply after Agree

- It is not the movement operations that are optional; rather, it is the point of the derivation at which they apply. Either they apply early enough to feed Agree or they come too late do have this effect.

3.5 Advantages of the ordering approach

The ordering approach ...

- presents the first uniform analysis of all four patterns of reflexes of successive-cyclic movement. Variation is due to reordering of operation-inducing features; languages do not have to differ in the locality of movement.
- can easily account for mixed patterns and optionality of patterns.

The ordering approach presupposes

- (i) a distinction between final and intermediate movement steps that the ordering principles of the grammar can refer to, and
- (ii) ordering of operation-inducing features.

Assumption (i) is indispensable in every approach that tries to account for the patterns of reflexes of movement. Patterns II and III provide empirical evidence for this split of movement types.

Assumption (ii) is required independently because Merge and Agree, when triggered by a single head, can interact transparently (feeding, bleeding).

Addition: It is not only Agree and Merge that are ordered relative to each other; rather, a more fine-grained approach is needed that distinguishes between different types of Merge.

4 General implications

4.1 Extrinsic vs. intrinsic ordering

BACKGROUND:

A central research question in frameworks that work with sequential application has been whether the order of rules must be fixed in a language-specific fashion (extrinsic / parochial ordering) or whether it follows from independent principles of the grammar (intrinsic / universal ordering).

PRINCIPLES:

- (i) SPECIFICITY: The more specific rule applies before the less specific rule.
(see among many others Anderson 1969; Kiparsky 1973*b*; Koutsoudas et al. 1974; Anderson 1992; Lahne 2012)
- (ii) COMPLEXITY: The less complex rule applies before the more complex rule.
(e.g. *Merge before Move*, Chomsky 1995; 2000, but see Chomsky 2013 for a different view)
- (iii) OBLIGATORINESS: Obligatory rules apply before optional rules.
(Ringen 1972; Perlmutter and Soames 1979)
- (iv) HIERARCHY-GOVERNED ORDERING: Domains of syntactic structure are ordered on a hierarchy such that a rule in a domain D_1 precedes a rule in a domain D_2 if D_1 is higher on the hierarchy than D_2 .
(Williams 1974; 2003; Grohmann 2003; Abels 2008)
- (v) THE CYCLE: Rules affecting a cyclic domain α apply before rules in a cyclic domain β if α is contained in β (first introduced in Chomsky et al. 1956).

TWO MAJOR VIEWS:

1. Chomsky (1965): Extrinsic ordering is required in addition to intrinsic ordering.
2. Pullum (1979): There is no need for extrinsic ordering; all orderings are determined by universal principles:

- (40) *Universally Determined Rule Application (UDRA, Pullum 1979: 18):*
All restrictions on the application of rules are determined by universal principles.

AN ARGUMENT FROM REFLEXES OF MOVEMENT:

- If there are two rules A and B, the principles predict either $A > B$ or $B > A$.
 - However, some orders of $[\bullet F \bullet]$, $[\bullet EF \bullet]$, $[*F \square *]$ are the exact opposite of one another, cf. (41).
 - No principle can predict $A > B$ and $B > A$ at the same time.
 - Consequences: The order of the operation-inducing features must be extrinsic. Thus, extrinsic ordering is needed in addition to intrinsic ordering.
- (41) Attested orders of final and intermediate movement triggers relative to a probe:
- a. pattern I order $[\bullet F \bullet], [\bullet EF \bullet] > [*F *]$
 - b. pattern II order $[\bullet F \bullet] > [*F *] > [\bullet EF \bullet]$
 - c. pattern III order $[\bullet EF \bullet] > [*F *] > [\bullet F \bullet]$
 - d. pattern IV order $[*F *] > [\bullet F \bullet], [\bullet EF \bullet]$

A NOTE ON THE CYCLE:

- The Cycle does not make any predictions about the order of rules / operations that apply within the same cyclic domain.
- cyclic domains: S, NP (Chomsky 1965), XP (Chomsky 1973), every projection is a cyclic node (McCawley 1984; 1988)
- In the configuration under investigation (Merge and Agree are triggered by the same head), the Cycle is *too weak* even in its strongest form with every projection being a cyclic node: Merge and Agree apply within the same cyclic domain (Řezač 2004).
- This is actually a good result; otherwise, the Cycle would preclude some of the attested orders of operation-inducing features.

4.2 The timing of edge feature-discharge

PROPOSALS IN THE LITERATURE:

- Chomsky (2000; 2001): Edge features can be inserted on the head of a phase if the phase has discharged all of its operation-inducing features. \leftrightarrow Intermediate movement steps are the last operation triggered by a phase head.
- Müller (2010; 2011): An edge feature can be inserted on a phase head as long as it still has an operation-inducing feature. Features are ordered on a stack; the edge feature is put on top of the stack and is discharged immediately afterwards. \leftrightarrow Intermediate movement steps cannot be the last operation triggered by a phase head.

A CONFLICT:

Both of these proposals are in conflict with some of the attested orders in (41). Intermediate movement steps can apply at various points of the derivation.

(42) *Orderings that conflict with the timing of edge feature insertion:*

- a. Intermediate movement steps are the last operation in a phase
(Chomsky 2000; 2001):

ζ [$\bullet F \bullet$], [$\bullet EF \bullet$] > [$*F:\square*$]	<i>pattern I order</i>
ζ [$\bullet EF \bullet$] > [$*F:\square*$] > [$\bullet F \bullet$]	<i>pattern III order</i>
- b. Intermediate movement steps are not the last operation in a phase
(Müller 2010; 2011):

ζ [$\bullet F \bullet$] > [$*F:\square*$] > [$\bullet EF \bullet$]	<i>pattern II order</i>
ζ [$*F:\square*$] > [$\bullet F \bullet$] > [$\bullet EF \bullet$]	<i>pattern IV order</i>

Thus, the timing of edge feature discharge must be more flexible, it cannot be universally fixed. In the present approach, the timing of intermediate movement steps is determined by extrinsic ordering.

5 Previous analyses of PI vs. PII

OPACITY BY ENRICHED REPRESENTATIONS:

A common strategy to derive opacity effects was to enrich representations with empty elements (traces, pro, indices) to encode what would correspond to previous stages of the derivation.

Example: The counter-bleeding interaction of *Reflexivization* and *Imperative Subject Deletion* in English (see e.g. Postal 1964; Lakoff 1968; Perlmutter and Soames 1979; McCawley 1988):

- (43) a. Defend yourself!
b. DS: pro_i defend you $_i$

ANALYSES OF PATTERNS I VS. II:

- assume that there is successive-cyclic movement in both pattern I and pattern II languages, viz. it is acknowledged that pattern II is opaque.
- are formulated in the GB-framework.
- make use of enriched representations.
- strategies:
 - (AI) Traces can or cannot be agreement controllers (Chung 1998).
 - (AII) A special type of empty element is left in intermediate positions (Haik et al. 1985; Tuller 1986; Haik 1990; Biloa 1993; Ouhalla 1993).
 - (AIII) Operations can apply to empty elements in intermediate positions (Haik 1990; Collins 1993).

5.1 AI: traces as agreement controllers

ASSUMPTIONS:

- Agreement between a head and an XP in its specifier takes place at S-structure.
- Pattern I: Traces are taken into account, they are agreement controllers.
- Pattern II: Traces in intermediate positions are ignored for the agreement rule; hence, only the XP in final position can trigger agreement.
- Hence, variation arises because languages differ as to whether traces are agreement controllers.

PROBLEMS WITH THIS APPROACH:

- mixed patterns: If a language has both a pattern I and a pattern II reflex, traces left by one and the same instance of \bar{A} -movement must count as agreement controllers and at the same time they must not.

5.2 AII: the \bar{A} -binding approach

ASSUMPTIONS:

- The approach is based on \bar{A} -binding (Aoun 1985; 1986; Finer 1985; Aoun and Li 1989).
- The special exponent that occurs under \bar{A} -movement is an anaphoric element that needs to be locally bound by an element in an \bar{A} -position.
- If there is movement of an XP to the local SpecCP, the anaphor is bound and thus licensed; if there is no movement, ungrammaticality results.
- Pattern I vs. pattern II: In pattern I languages, traces in intermediate positions can act as binders; in pattern II languages, they cannot be binders.

- Hence, variation is due to the fact that there are two different types of empty elements (binders and non-binders).

(44) *Pattern I: traces are \bar{A} -binders:*

$$\begin{array}{ccc} \text{[CP XP}_k \text{ [C' ... R}_{+anaph} \text{ ... V [CP t}_k \text{ [C' ... R}_{+anaph} \text{ ... V t}_k \text{]]]]} & & \\ \downarrow \bar{A}\text{-binding} \uparrow & & \downarrow \bar{A}\text{-binding} \uparrow \end{array}$$

(45) *Pattern II: traces are not \bar{A} -binders:*

$$\begin{array}{ccc} \text{[CP XP}_k \text{ [C' ... R}_{+anaph} \text{ ... V [CP t}_k \text{ [C' ... R}_{+anaph} \text{ ... V t}_k \text{]]]]} & & \\ \downarrow \bar{A}\text{-binding} \uparrow & & \downarrow * \bar{A}\text{-binding} \uparrow \end{array}$$

PROBLEMS WITH AII:

- mixed patterns: If a language has both a pattern I and a pattern II reflex of movement, traces must be able to be binders and must not be binders at the same time.
- pattern III: If the \bar{A} -binding approach is extended to pattern III, the antecedent must not be able to act as a binder, against standard assumptions.

5.3 AIII: Operations on empty elements

ASSUMPTIONS:

- Traces in intermediate positions share certain features with their antecedent (at least those that are relevant for the reflex of movement).
- Traces are always agreement controllers.
- Prediction: pattern I reflexes.
- Pattern II: There is an operation that manipulates the features of the trace before agreement applies. Haik (1990): The (relevant features of) traces are deleted. Consequently, there can be no successful agreement in non-final clauses.

PROBLEMS WITH THIS APPROACH:

- mixed patterns: Traces left by a single instance of \bar{A} -movement must undergo deletion and must not do so at the same time.

CONCLUSION:

On the empirical side, the existing approaches to the variation between patterns of I and II cannot account for mixed patterns, and at least the \bar{A} -binding approach cannot easily be extended to pattern III. From a conceptual point of view, the analyses are rather complex because they require (different types) of empty elements (binders/non-binders, agreement controllers/non-agreement controllers) or operations on empty elements.

5.4 A Minimalist reformulation

QUESTION:

Can the GB analyses be transferred to Minimalism?

CHALLENGES:

- no traces anymore
- no designated S-structure anymore

Late agreement:

Agree is a postsyntactic PF-operation (cf. Marantz 1991; Ackema and Neeleman 2004; Fuß 2007; Bobaljik 2008; Miyagawa 2010 among others).

Elements in intermediate landing sites:

(a) the copy theory of movement (Chomsky 1995)

(46) $[_{CP} \mathbf{XP} [_{C'} C [_{TP} T [_{vP} \mathbf{XP} [_{v'} DP_{ext} [_{v'} v [_{VP} V \mathbf{XP}]]]]]]]]]]$

(b) no intermediate representation (Epstein and Seely 2002)

(47) $[_{CP} \mathbf{XP} [_{C'} C [_{TP} T [_{vP} \square [_{v'} DP_{ext} [_{v'} v [_{VP} V \square]]]]]]]]]]$

(c) the multi-dominance approach (McCawley 1982; Gärtner 2002; Starke 2001; Frampton 2004; Abels 2004; 2012; Citko 2005; Wilder 2008; Gracanin-Yuksek 2009; de Vries 2013; Johnson 2009)

(48) *Multi-dominance approach to movement:*

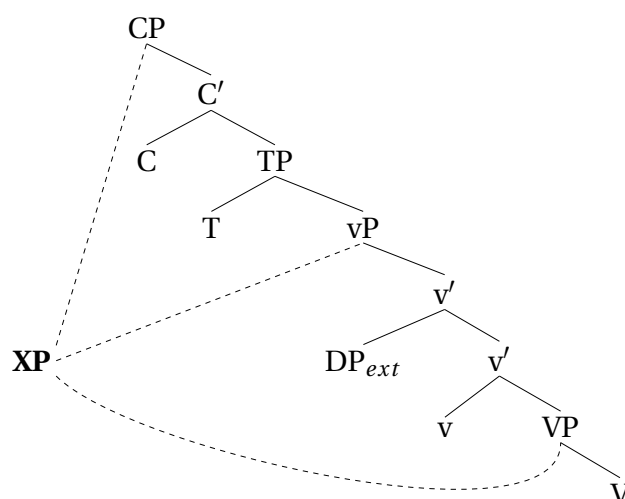

PROBLEMS FOR THE MINIMALIST VERSIONS OF THE ENRICHED REPRESENTATION ANALYSES:

- Nothing left behind: None of the three approaches AI – AIII can be formulated if movement does not leave behind anything – there is nothing to Agree with in intermediate positions. Hence, patterns I and III cannot be derived, only pattern II follows.
- Multi-dominance approach/copy theory: How can occurrences of a moved XP in the final and the intermediate landing sites be distinguished (i) if there is only a single occurrence of XP (multi-dominance approach) or (ii) if copies of XP are completely identical to the XP they are copies of (cf. Chomsky 1995)?³
- multi-dominance approach: If an operation applies to XP, as in AIII, all positions are affected; hence, the required distinction between the final and intermediate landing sites is lost.
- Copy theory: It is possible to translate the approaches if copies in final and intermediate positions can be distinguished.

³The following solutions to this problem have been proposed: Abels (2012: 144), working within a multi-dominance approach, defines the final position of a remerged XP as follows: The highest occurrence of XP is the one whose mother dominates all other occurrences of XP. As for the copy theory of movement, Nunes (2004: 70ff.) proposes that feature checking (or feature valuation) affects only the copy in the final position. Copies in intermediate positions still contain unchecked features. Thus, final and intermediate positions can be distinguished by making reference to the status of their features (checked vs. unchecked). Chains are unified only at LF.

CONCLUSIONS:

- Previous approaches to pattern I vs. pattern II reflexes can only be reformulated under the copy theory of movement if (i) the copies in the final and the intermediate landing sites can be distinguished, and (ii) if Agree applies after movement (probably at PF) and thus counter-cyclic (for patterns I and III).
- What is still required in addition are different types of intermediate copies (in the \bar{A} -binding approach) or operations on intermediate copies.
- But even then we still have a problem to account for mixed patterns.

The ordering approach ...

- can easily account for mixed patterns.
- neither requires empty elements like traces in intermediate positions, nor operations applying to them, nor is there any reference to levels of representation.
- is compatible with all Minimalist theories of movement (copy theory, multi-dominance, nothing left by movement) because it is only important *when* a phrase moves, not *how* movement is implemented.

6 Conclusions

- Observation: Merge to SpecHP can both feed and counter-feed Agree initiated by a head H.
- Merge > Agree > Merge suggests that different types of Merge must be distinguished (here, by their trigger, but this can be implemented differently, see e.g. Bošković 2007; Heck and Müller 2003).
- Patterns of reflexes of movement provide evidence for a split between final and intermediate movement steps in a movement chain.
- The patterns follow from reordering of operation-inducing features on the head H.
- The approach presents the first uniform analysis of all four patterns. In addition, it can account for mixed patterns and optionality.
- In contrast to previous analysis it does not require enriched representations or operations on empty elements.
- The cross-linguistic variation provides an argument for extrinsic ordering of operations.
- Since it is based on the timing of operations, the approach presents a strong argument for a strictly derivational grammar.

References

- Abels, Klaus (2004): Right Node Raising: Ellipsis or Across the Board Movement?. In: K. Moulton and M. Wolf, eds, *Proceedings of NELS 34*. GLSA, Amherst, Mass, pp. 45–60.
- Abels, Klaus (2008): 'Towards A Restrictive Rtheory of (Remnant) Movement', *Linguistic Variation Yearbook 7*, 53–120.
- Abels, Klaus (2012): *Phases: An essay on cyclicity in syntax*. Linguistische Arbeiten 543, de Gruyter, Berlin.
- Abels, Klaus and Peter Muriungi (2008): 'The focus marker in Kĩitharaka: Syntax and semantics', *Lingua 118*, 687–731.
- Ackema, Peter and Ad Neeleman (2004): *Beyond Morphology: Interface Conditions on Word Formation*. Vol. 6 of *Oxford Studies in Theoretical Linguistics*, Oxford University Press, Oxford.
- Anand, Pranav and Andrew Nevins (2005): The locus of ergative case assignment: Evidence from scope. In: A. Johns, D. Massam and J. Ndayiragije, eds, *Ergativity: Emerging issues*. Kluwer, Dordrecht, pp. 3–27.
- Anderson, Stephen R. (1969): West Scandinavian vowel systems and the ordering of phonological rules. PhD thesis, MIT, Cambridge, Mass.
- Anderson, Stephen R. (1992): *A-Morphous Morphology*. Cambridge University Press, Cambridge, Mass.
- Aoun, Joseph (1985): *A grammar of anaphora*. Linguistic Inquiry Monographs 11, MIT Press, Cambridge, Mass.
- Aoun, Joseph (1986): *Generalized binding*. Foris, Dordrecht.
- Aoun, Joseph and Audrey Li (1989): 'Scope and constituency', *Linguistic Inquiry 20*, 219–251.
- Asarina, Alya (2011): Case in Uyghur and beyond. PhD thesis, MIT, Cambridge, Mass.
- Assmann, Anke, Doreen Georgi, Fabian Heck, Gereon Müller and Philipp Weisser (2012): Ergatives Move Too Early: On an Instance of Opacity in Syntax. Ms., Universität Leipzig, available at LingBuzz: lingbuzz/001646. To appear in *Syntax*.
- Baker, Mark C. (2008): *The Syntax of Agreement and Concord*. Vol. 115 of *Cambridge Studies in Linguistics*, Cambridge University Press, Cambridge.
- Bilola, Edmond (1993): Clitic Climbing in Bantu. In: S. Mufwene and L. Moshi, eds, *Topics in African Linguistics. Papers from the XXI Annual Conference on African Linguistics, University of Georgia, April 1990*. John Benjamins, Amsterdam, pp. 67–77.
- Bobaljik, Jonathan (2008): Where's Phi? Agreement as a Post-Syntactic Operation. In: D. Harbour, D. Adger and S. Béjar, eds, *Phi-Theory: Phi Features Across Interfaces and Modules*. Oxford University Press, Oxford, pp. 295–328.
- Boeckx, Cedric (2008): *Understanding Minimalist Syntax: Lessons from Locality in Long-Distance Dependencies*. Vol. 9 of *Generative Syntax*, Blackwell Publishing, London.
- Bošković, Željko (2007): 'On the Locality and Motivation of Move and Agree: An Even More Minimal Theory', *Linguistic Inquiry 38*, 589–644.
- Bruening, Benjamin (2005): The Algonquian Inverse is Syntactic: Binding in Passamaquoddy. Ms., University of Delaware.
- Cheng, Lisa Lai-Shen (2006): Decomposing Bantu Relatives. In: C. Davis, A. R. Deal and Y. Zabbal, eds, *Proceedings of NELS 36*. GLSA, Amherst, Mass, pp. 197–215.
- Chomsky, Noam (1965): *Aspects of the Theory of Syntax*. MIT Press, Cambridge, Mass.
- Chomsky, Noam (1973): Conditions on Transformations. In: S. Anderson and P. Kiparsky, eds, *A Festschrift for Morris Halle*. Academic Press, New York, pp. 232–286.
- Chomsky, Noam (1995): *The Minimalist Program*. MIT Press, Cambridge, Mass.
- Chomsky, Noam (2000): Minimalist Inquiries: The Framework. In: M. Roger, M. David and J. Uriagereka, eds, *Step by Step*. MIT Press, Cambridge, Mass., pp. 89–155.
- Chomsky, Noam (2001): Derivation by Phase. In: M. Kenstowicz, ed., *Ken Hale: A Life in Language*. MIT Press, Cambridge, Mass., pp. 1–52.
- Chomsky, Noam (2013): 'Problems of projection', *Lingua 130*, 33–49.
- Chomsky, Noam, Morris Halle and Fred Lukoff (1956): On Accent and Juncture in English. In: M. Halle, H. Lunt and C. McLean, H. van Schooneveld, eds, *For Roman Jakobson. Essays on the occasion of his sixtieth birthday*. Mouton, The Hague, pp. 65–80.
- Chung, Sandra (1998): *The Design of Agreement: Evidence from Chamorro*. University of Chicago Press, Chicago.
- Chung, Sandra and James McCloskey (1987): 'Government, barriers and small clauses in Modern Irish', *Linguistic Inquiry 18*, 173–237.
- Citko, Barbara (2005): 'On the Nature of Merge: External Merge, Internal Merge, and Parallel Merge', *Linguistic Inquiry 36*, 475–496.
- Clements, George (1984a): 'Binding Domains in Kikuyu', *Studies in the Linguistic Sciences 14*, 37–56.

- Clements, George (1984*b*): Principles of Tone Assignment in Kikuyu. In: G. Clements and J. Goldsmith, eds, *Autosegmental Studies in Bantu Tone*. Foris, Dordrecht, pp. 281–339. Publications in African Languages and Linguistics.
- Clements, George and Kevin Ford (1979): ‘Kikuyu Tone Shift and its Synchronic Consequences’, *Linguistic Inquiry* **10**, 179–210.
- Collins, Christopher (1993): Topics in Ewe Syntax. PhD thesis, MIT, Cambridge, Mass.
- Collins, Christopher (1994): ‘Economy of Derivation and the Generalized Proper Binding Condition’, *Linguistic Inquiry* **25**, 45–61.
- de Vries, Marc (2013): ‘Multidominance and Locality’, *Lingua* **134**, 149–169.
- Épée, Roger (1976*a*): Generative Syntactic Studies in Duala. PhD thesis, Cornell University, NY.
- Épée, Roger (1976*b*): ‘On Some Rules That Are Not Successive Cyclic in Duala’, *Linguistic Inquiry* **7**, 193–198.
- Epstein, Samuel D. and Daniel T. Seely (2002): Rule Applications as Cycles in a Level-Free Syntax. In: S. Epstein and T. Seely, eds, *Derivation and Explanation in the Minimalist Program*. Blackwell, Oxford, pp. 65–89.
- Finer, Daniel L. (1985): ‘The Syntax of Switch-Reference’, *Linguistic Inquiry* **16**, 35–55.
- Frampton, John (2004): Copies, Traces, Occurrences, and All That. Ms., Northeastern University.
- Fuß, Eric (2007): Cyclic Spell-Out and the domain of post-syntactic operations: Evidence from complementizer agreement. In: K. Grohmann, ed., *Dynamic interface*. Special issue of Linguistic Analysis Vol. 33.3-4, pp. 267–302.
- Gärtner, Hans-Martin (2002): *Generalized Transformations and Beyond*. Akademie-Verlag, Berlin.
- Georgi, Doreen (2014): Opaque Interactions of Merge and Agree. On the Nature and Order of Elementary Operations. PhD thesis, Leipzig University.
- Gracanin-Yukse, Martina (2009): What And Why Can’t Be Shared. Ms., Middle East Technical University.
- Grohmann, Kleanthes (2003): *Prolific Domains: On the Anti-Locality of Movement Dependencies*. John Benjamins, Amsterdam, Philadelphia.
- Haïk, Isabelle (1990): ‘Anaphoric, Pronominal and Referential INFL’, *Natural Language and Linguistic Theory* **8**, 347–374.
- Haïk, Isabelle, Hilda Koopman and Dominique Sportiche (1985): ‘INFL en mooré et le liage dans le système A’, Rapport de recherches du groupe de linguistique africaniste, année 1985-1986. Montréal.
- Halle, Morris and Alec Marantz (1993): Distributed Morphology and the Pieces of Inflection. In: K. Hale and S. J. Keyser, eds, *The View from Building 20*. MIT Press, Cambridge, Mass., pp. 111–176.
- Halle, Morris and Alec Marantz (1994): Some Key Features of Distributed Morphology. In: A. Carnie, H. Harley and T. Bures, eds, *Papers on Phonology and Morphology*. Vol. 21 of *MIT Working Papers in Linguistics*, MITWPL, Cambridge, Mass., pp. 275–288.
- Halpert, Claire (2012): Argument licensing and agreement in Zulu. PhD thesis, MIT, Cambridge, Mass.
- Heck, Fabian and Gereon Müller (2003): ‘Derivational Optimization of Wh-Movement’, *Linguistic Analysis* **33**, 97–148. (Volume appeared 2007).
- Heck, Fabian and Gereon Müller (2007): Extremely Local Optimization. In: E. Brainbridge and B. Agbayani, eds, *Proceedings of the 26th WECOL*. California State University, Fresno, pp. 170–183.
- Henry, Alison (1995): *Belfast English and Standard English: Dialect Variation and Parameter Setting*. Oxford Studies in Comparative Syntax, Oxford University Press, New York.
- Johnson, Kyle (2009): Why Movement. Ms., University of Massachusetts.
- Kalin, Laura and Coppe van Urk (2012): Aspect-based agreement reversal in Neo-Aramaic. Handout of a talk at WCCFL 30.
- Kenstowicz, Michael and Charles Kisseberth (1979): *Generative Phonology*. Academic Press, New York.
- Kinyalolo, Kasangani K.W. (1991): Syntactic dependencies and the Spec-head agreement hypothesis in Kilega. PhD thesis, UCLA, Los Angeles.
- Kiparsky, Paul (1968): Linguistic universals and linguistic change. In: E. Bach and R. Harms, eds, *Universals in Linguistic Theory*. Holt, New York, pp. 170–210.
- Kiparsky, Paul (1971): Historical linguistics. In: W. Dingwall, ed., *A Survey of Linguistic Science*. University of Maryland Linguistics Program, College Park, pp. 576–642.
- Kiparsky, Paul (1973*a*): Abstractness, Opacity, and Global Rules. In: O. Fujimura, ed., *Three Dimensions in Linguistic Theory*. TEC, Tokyo, pp. 57–86.
- Kiparsky, Paul (1973*b*): “Elsewhere” in Phonology. In: S. Anderson and P. Kiparsky, eds, *A Festschrift for Morris Halle*. Holt, Rinehart and Winston, pp. 93–106.
- Kisseberth, Charles W. (1972*a*): ‘Cyclical Rules in Klamath Phonology’, *Linguistic Inquiry* **3**, 3–33.
- Koutsoudas, Andreas, Gerald Sanders and Craig Noll (1974): ‘The application of phonological rules’, *Language* **50**, 1–28.

- Lahne, Antje (2008a): Excluding SVO in Ergative Languages: A New View on Mahajan's Generalisation. In: F. Heck, G. Müller and J. Trommer, eds, *Varieties of Competition*. Universität Leipzig, Institut für Linguistik, pp. 65–80. Vol. 87 of *Linguistische Arbeitsberichte*.
- Lahne, Antje (2008b): Where There is Fire There is Smoke. Local Modelling of Successive-Cyclic Movement. PhD thesis, Universität Leipzig, Leipzig.
- Lahne, Antje (2012): Specificity-driven Syntactic Derivation. In: M. Uribe-Etxebarria and V. Valmala, eds, *Ways of Structure Building*. Oxford University Press, Oxford, pp. 271–296.
- Lakoff, George (1968): *Deep surface grammar*. Indiana University Linguistics Club, Bloomington, Ind.
- Marantz, Alec (1991): Case and Licensing. In: G. Westphal, B. Ao and H.-R. Chae, eds, *Proceedings of the Eighth Eastern States Conference on Linguistics*. University of Maryland, pp. 234–253.
- Martinović, Martina (2013): Wh-Morphology and Cyclicity in Wolof. Ms., University of Chicago, available at LingBuzz: lingbuzz/001874.
- McCawley, James D. (1982): 'Parentheticals and Discontinuous Constituent Structure', *Linguistic Inquiry* **13**, 91–106.
- McCawley, James D. (1984): Exploitation of the cyclic principle as a research strategy in syntax. In: W. de Geest and Y. Putseys, eds, *Sentential complementation*. Foris, Dordrecht, pp. 165–183.
- McCawley, James D. (1988): *The Syntactic Phenomena of English*. Vol. 1, University of Chicago Press, Chicago.
- McCloskey, James (1979): *Transformational Syntax and Model Theoretic Semantics. A Case Study in Modern Irish*. Reidel, Dordrecht.
- McCloskey, James (1990): Resumptive pronouns, \bar{A} -binding and levels of representation in Irish. In: R. Hendrick, ed., *Syntax of the Modern Celtic Languages*. Academic Press, New York and San Diego, pp. 199–248. Vol. 23 of *Syntax and Semantics*.
- McCloskey, James (2002): Resumption, successive cyclicity, and the locality of operations. In: S. Epstein and T. Seely, eds, *Derivation and Explanation in the Minimalist Program*. Blackwell, Oxford, pp. 184–226.
- Miyagawa, Shigeru (2010): *Why Agree? Why Move? Unifying Agreement-based and Discourse Configurational Languages*. Linguistic Inquiry Monograph 54, MIT Press.
- Müller, Gereon (1999): 'Imperfect Checking', *The Linguistic Review* **16**, 359–404.
- Müller, Gereon (2009): Ergativity, Accusativity, and the Order of Merge and Agree. In: K. Grohmann, ed., *Explorations of Phase Theory. Features and Arguments*. Mouton de Gruyter, Berlin, pp. 269–308.
- Müller, Gereon (2010): 'On Deriving CED Effects from the PIC', *Linguistic Inquiry* **41**, 35–82.
- Müller, Gereon (2011): *Constraints on Displacement: A phase-based approach*. John Benjamins, Amsterdam.
- Muriungi, Peter (2005): 'Wh-Questions in Kitharaka', *Studies in African Linguistics* **34**, 43–104.
- Nunes, Jairo (2004): *Linearization of chains and sideward movement*. Linguistic Inquiry Monographs 43, MIT Press, Cambridge, Mass.
- Ormazabal, Javier, Juan Uriagereka and Myriam Uribe-Etxebarria (1994): Word Order and Wh-Movement: Towards a Parametric Account. Ms., University of Connecticut, University of Maryland.
- Ouhalla, Jamal (1993): 'Subject-Extraction, Negation and the Antiagreement Effect', *Natural Language and Linguistic Theory* **11**, 477–518.
- Perlmutter, David and Scott Soames (1979): *Syntactic Argumentation and the Structure of English*. The University of California Press, Berkeley.
- Pesetsky, David (1989): 'Language-particular Processes and the Earliness Principle', Ms., MIT.
- Postal, Paul (1964): 'Underlying and superficial linguistic structure', *Harvard Educational Review* **34**, 246–266.
- Preminger, Omer (2011): Agreement as a Fallible Operation. PhD thesis, MIT, Cambridge, Mass.
- Pullum, Geoffrey K. (1979): *Rule Interaction and the Organization of a Grammar*. Garland, New York & London. (PhD thesis from 1976, University of London).
- Reintges, Chris H., Philip LeSourd and Sandra Chung (2006): Movement, Wh-Agreement, and Apparent Wh-in-Situ. In: L. Cheng and N. Corver, eds, *Wh-Movement: Moving On*. MIT Press, Cambridge, Mass., chapter 7, pp. 165–194.
- Richards, Norvin (2013): 'Lardil "Case Stacking" and the Timing of Case Assignment', *Syntax* **16**, 42–76.
- Ringen, Catherine (1972): 'On Arguments for Rule Ordering', *Foundations of Language* **8**, 266–273.
- Rizzi, Luigi (1990): *Relativized Minimality*. MIT Press, Cambridge, Mass. Linguistic Inquiry Monographs 16.
- Sabel, Joachim (2000): Partial Wh-Movement and The Typology of Wh-Questions. In: U. Lutz, G. Müller and A. von Stechow, eds, *Wh-Scope Marking*. John Benjamins, Amsterdam, pp. 409–446.
- Saddy, Douglas (1991): Wh-Scope Mechanisms in Bahasa Indonesia. In: L. Cheng and H. Demirdache, eds, *More papers on wh-movement (MITWPL 15)*. MIT Press, Cambridge, Mass., pp. 183–218.

- Schneider-Zioga, Patricia (1995): 'Specifier/Head Agreement in Kinande', *Cahiers Linguistiques d'Ottawa* **23**, 67–96.
- Starke, Michal (2001): Move Dissolves Into Merge: A Theory of Locality. PhD thesis, University of Geneva.
- Sternefeld, Wolfgang (2006): *Syntax: Eine morphologisch motivierte generative Beschreibung des Deutschen*. Stauffenburg, Tübingen. Two volumes.
- Takahashi, Shoichi and Martina Gracanin Yuksek (2008): 'Morphosyntax of Movement Dependencies in Haitian Creole', *Syntax* **11**, 223–250.
- Torrego, Esther (1984): 'On Inversion in Spanish and Some of Its Effects', *Linguistic Inquiry* **15**, 103–129.
- Torrence, Harold (2012): 'The morpho-syntax of silent wh-expressions in Wolof', *Natural Language and Linguistic Theory* **30**, 1147–1184.
- Torrence, Harold (2013): The Morphosyntax of Wolof Clefts: Structure and Movement. In: K. Hartmann and T. Veenstra, eds, *Cleft Structures*. John Benjamins, Amsterdam, pp. 187–223.
- Tuller, Laurice Anne (1986): Bijjective Relations in Universal Grammar and the Syntax of Hausa. PhD thesis, UCLA, Los Angeles, CA.
- van Koppen, Marjo (2005): One Probe – Two Goals: Aspects of agreement in Dutch dialects. PhD thesis, Leiden University, Leiden. LOT-publications number 105.
- van Urk, Coppe and Norvin Richards (2013): Two components of long-distance extraction: Successive cyclicity in Dinka. Ms., MIT, available at LingBuzz: lingbuzz/001766.
- Řezač, Milan (2004): Elements of Cyclic Agree: Agree and Merge. PhD thesis, University of Toronto.
- Wilder, Chris (2008): Shared Constituents and Linearization. In: K. Johnson, ed., *Topics in Ellipsis*. Cambridge University Press, pp. 229–258.
- Williams, Edwin S. (1974): Rule ordering in syntax. PhD thesis, MIT, Cambridge, Mass.
- Williams, Edwin S. (2003): *Representation Theory*. MIT Press, Cambridge, Mass.